

P3 565 Series Cables Product Descriptions

CommScope's P3® product line is the industry standard by which all coaxial trunk and distribution cables are measured. P3 has been proven robust and reliable by years of successful installations.

P3 565 is optimized for use in broadband feeder plants. A thinner aluminum shield contributes to lower cable weight, while a slightly larger diameter impacts cable attenuation.

Standard P3 Construction

A solid aluminum tube is precision swagged onto a high compression, micro-cellular foam dielectric core. The core contains a fully bonded copper clad center conductor.

Aerial Installation				
Part #	Description	Cable Weight	Shipping Wteight	Standard Length
P3 565 JCA	Offers all of P3's standard construction features	112 lbs/kft (167 kg/km)	153 lbs/kft (228 kg/km)	2450 ft (747 m)
P3 565 JCAM 109	Has an integrated figure 8 galvanized solid steel messenger for self-supporting applications	144 lbs/kft (214 kg/km)	205 lbs/kft (305 kg/km)	2450 ft (747 m)
Underground Installation				
Part #	Description	Cable Weight	Shipping Wteight	Standard Length
P3 565 JCASS	Features CommScope's Migra-Heal floodant that seals jacket damage to inhibit corrosion	116 lbs/kft (173 kg/km)	157 lbs/kft (173 kg/km)	2450 ft (747 m)

P3 JCASS

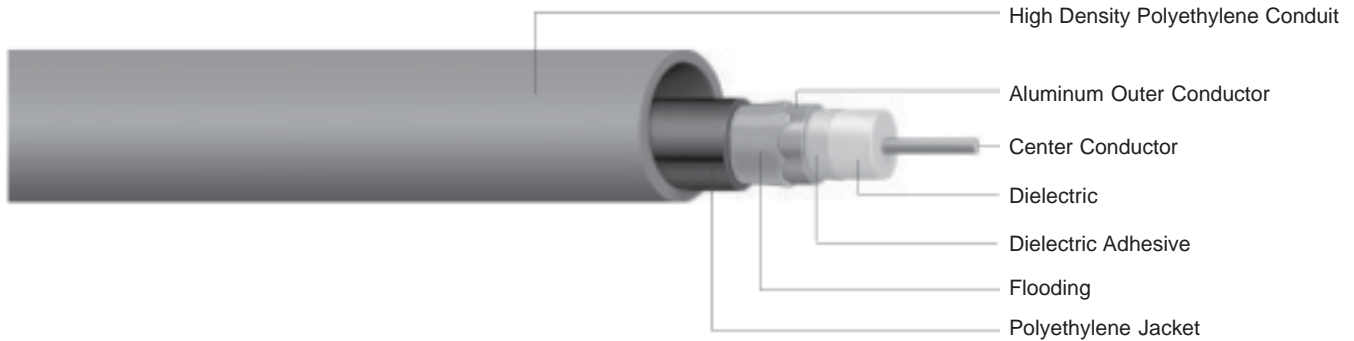

CommScope's P3® product line is the industry standard by which all coaxial trunk and distribution cables are measured. P3 has been proven robust and reliable by years of successful installations.

CommScope P3 offers low attenuation and inherent strength making it an industry standard.

CommScope offers several different sizes of P3 Cable-In-Conduit (500, 565, 625, 700, 750, 875 and 1000), each optimized for a specific use.

Size	Wall Thickness	Wall Rating	P3 500 JCASS			P3 565 JCASS			P3 625 JCASS		
			Nominal Length (ft)	Reel Size (FDT)(in)	Weight* lb/ft	Nominal Length (ft)	Reel Size (FDT)(in)	Weight* lb/ft	Nominal Length (ft)	Reel Size (FDT)(in)	Weight* lb/ft
1"	SDR 13.5	Medium	2,400	54x30x40	266	2,400	54x30x40	285	2,400	54x30x40	314
	SDR 11	Heavy	2,400	54x30x40	301	2,400	54x30x40	320	2,400	54x30x40	349
	SCH 40	X - Heavy	2,400	54x30x40	316	2,400	54x30x40	335	2,400	54x30x40	364
1 1/4"	SDR 13.5	Medium	2,400	63x30x40	362	2,400	63x30x40	381	2,400	63x30x40	410
	SCH 40	Heavy	2,400	63x30x40	392	2,400	63x30x40	411	2,400	63x30x40	440
	SDR 11	X - Heavy	2,400	63x30x40	417	2,400	63x30x40	436	2,400	63x30x40	465
1 1/2"	SDR 13.5	Medium	2,400	80x40x38	441	2,400	80x40x38	460	2,400	80x40x38	489
	SCH 40	Heavy	2,400	80x40x38	450	2,400	80x40x38	469	2,400	80x40x38	498
	SDR 11	X - Heavy	2,400	80x40x38	513	2,400	80x40x38	532	2,400	80x40x38	561
2"	SDR 13.5	Medium	2,400	90x42x40	569	2,400	90x42x40	588	2,400	90x42x40	617
	SCH 40	Heavy	2,400	90x42x40	629	2,400	90x42x40	648	2,400	90x42x40	677
	SDR 11	X - Heavy	2,400	90x42x40	737	2,400	90x42x40	756	2,400	90x42x40	785
			P3 700 JCASS			P3 750 JCASS			P3 875 JCASS		
1 1/4"	SDR 13.5	Medium	2,500	63x30x40	430	2,500	68x30x40	467	NA	NA	NA
	SCH 40	Heavy	2,500	63x30x40	460	2,500	68x30x40	497	NA	NA	NA
	SDR 11	X - Heavy	2,500	63x30x40	485	2,500	68x30x40	522	NA	NA	NA
1 1/2"	SDR 13.5	Medium	2,500	80x40x38	509	2,500	80x40x38	546	2,500	80x40x38	606
	SCH 40	Heavy	2,500	80x40x38	518	2,500	80x40x38	555	2,500	80x40x38	615
	SDR 11	X - Heavy	2,500	80x40x38	581	2,500	80x40x38	618	2,500	80x40x38	678
2"	SDR 13.5	Medium	2,500	90x42x40	637	2,500	90x42x40	674	2,500	90x42x40	734
	SCH 40	Heavy	2,500	90x42x40	697	2,500	90x42x40	734	2,500	90x42x40	794
	SDR 11	X - Heavy	2,500	90x42x40	805	2,500	90x42x40	842	2,500	90x42x40	902
			P3 1000 JCASS								
1 1/4"	SDR 13.5	Medium	NA	NA	NA						
	SCH 40	Heavy	NA	NA	NA						
	SDR 11	X - Heavy	NA	NA	NA						
1 1/2"	SDR 13.5	Medium	NA	NA	NA						
	SCH 40	Heavy	NA	NA	NA						
	SDR 11	X - Heavy	NA	NA	NA						
2"	SDR 13.5	Medium	2,400	90x42x40	843						
	SCH 40	Heavy	2,400	90x42x40	903						
	SDR 11	X - Heavy	2,400	90x42x40	1,011						

Trunk & Distribution Cable Catalog Numbering Key

P3 625 J CA M - 188

P3
 Size
 (diameter over shield)
 - 412 - 750
 - 500 - 840
 - 565 - 875
 - 625
 - 700
 PE Jacket
 Messenger
 Copper Aluminum
 Messenger Dia.

Suffix
 - J - Jacketed
 - CA - Copper Aluminum
 - SS - Miagra-Heal Flooding Compound
 - T - Trader
 - M - Messenger
 - EHS - Extra High Strength

P3 Aerial Construction Configurations

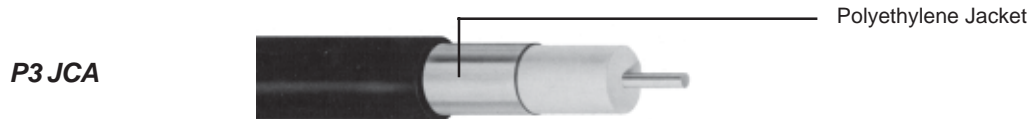
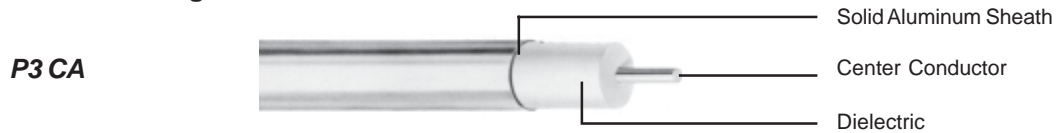

P3 Underground Construction Configurations

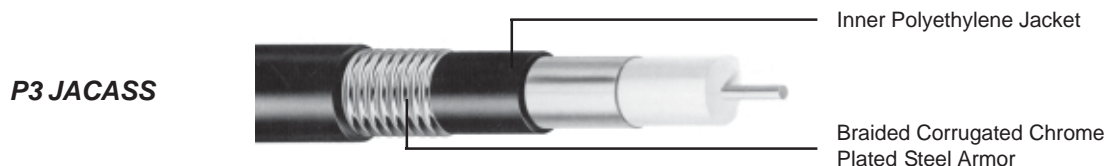
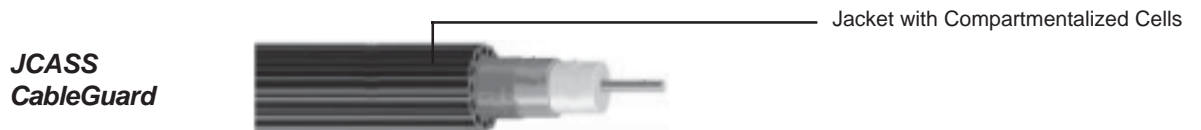
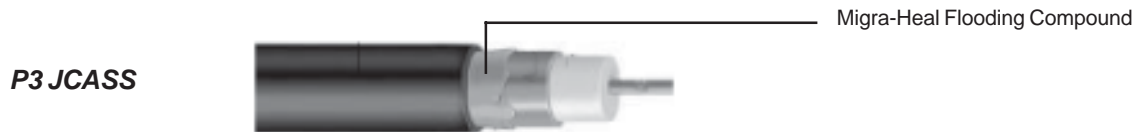

P3 565 Series Cables Product Specifications

Physical Dimensions		
Component	Inches	mm
Nominal Center Conductor Diameter	0.129	3.28
Nominal Diameter Over Dielectric	0.159	13.20
Nominal Diameter Over Outer Conductor	0.565	14.35
Nominal Outer Conductor Thickness	0.023	0.58
Jacketed Version		
Nominal Diameter Over jacket	0.625	15.86
Nominal Jacket Wall Thickness	0.030	0.76
Nominal Dia. Over Flooded Jacket (JCASS)	0.635	16.13
Messenger Version		
Diameter of Steel Messenger	0.109	2.77

Mechanical Characteristics		
Minimum Bending Radius	Bonded	
(Jacketed)	5.0 in	12.7 cm
Maximum Pulling Tension	350 lbs	159 kg _f
Minimum Breaking Strength of Messenger	(109) 1,800 lbs	816 kg _f

Electrical Characteristics		
Capacitance	15.3 ± 1.0 pf/ft	50 ± 3.0 nf/ft
Impedance	75 ohms	
Velocity of Propagation	89%	

Maximum D.C. Resistance @ 68°F (20°C)		
Inner Conductor	0.96 ohms/1000ft	3.15 ohms/km
Outer Conductor	0.34 ohms/1000ft.	1.12 ohms/km
Loop	1.30 ohms/1000ft	4.26 ohms/km

Attenuation @ 68°F (20°C)				
Frequency (Mhz)	(dB/100 ft)		dB/100 m)	
	Nom.	Max.	Nom.	Max.
5	0.13	0.14	0.13	0.46
30	0.33	0.34	1.08	1.12
45	0.40	0.41	1.31	1.35
50	0.43	0.45	1.41	1.48
55	0.46	0.47	1.51	1.54
83	0.56	0.58	1.84	1.90
108	0.64	0.66	2.10	2.17
150	0.76	0.79	2.49	2.59
181	0.84	0.88	2.76	2.89
193	0.87	0.90	2.85	2.95
211	0.91	0.95	2.98	3.12
220	0.93	0.98	3.05	3.22
250	0.99	1.03	3.25	3.38
270	1.03	1.07	3.38	3.51
300	1.09	1.13	3.58	3.71
325	1.13	1.18	3.71	3.87
350	1.18	1.23	3.87	4.04
375	1.22	1.27	4.00	4.17
400	1.27	1.32	4.17	4.33
425	1.31	1.37	4.30	4.49
450	1.35	1.40	4.43	4.59
500	1.43	1.49	4.69	4.89
550	1.50	1.56	4.92	5.12
600	1.58	1.64	5.18	5.38
750	1.78	1.85	5.84	6.07
865	1.93	2.00	6.33	6.56
1000	2.08	2.17	6.82	7.12